

DESCRIPTION:

PT62 float and thermostatic (internal air vent) steam traps are designed for draining condensate from all types of low and medium pressure steam heating and process equipment.

Typical applications include unit heaters, heat exchangers, driers and jacketed vessels.

Horizontal installation.

AVAILABLE TYPES:

PT 62 - with thermostatic air vent

PT 62S- SLR (with steam lock release)

PT 62C - with thermostatic air vent and SLR.

FEATURES:

Modulating discharge.

Discharges condensate at steam temperature.

Excellent air venting (by thermostatic air vent).

USE: Saturated and superheated steam.

SIZES: DN15, 20, 25

CONNECTIONS: Screwed (NPT, BSPT, BSP)
Flanged*/ Socket Weld

*End connection flanges of ASTM A105 forged carbon steel are welded on.

Non IBR¹ / IBR

LIMITING CONDITIONS:

PMA: Max allowable pressure	16 bar(g)
TMA: Max. allowable temperature	220 °C
PMO: Max operating pressure	14 bar(g)
TMO: Max. operating temperature	220 °C
Body shell design rating	20 bar(g) 426 °C
Cold hydro test pressure	32 bar(g)



INSTALLATION:

Horizontal installation with flow from left to right.

The trap should be installed horizontally below the drain point of the equipment in a position such that the float arm is in a horizontal plane and the float rises and falls vertically, with the flow direction as indicated on the cover.

The word 'TOP' on the nameplate indicates the top side of the trap.

Max. differential pressure range:

PT62-4.5 : 4.5 bar

PT62-10 : 10 bar

PT62-14 : 14 bar

TRAP DISCHARGE CAPACITY IN kg/hr

MODEL	SIZE	DIFFERENTIAL PRESSURE (bar)																
		0.5	1.0	1.5	2.0	3.0	4.0	4.5	5.0	6.0	7.0	8.0	9.0	10.0	11.0	12.0	13.0	14.0
PT62-4.5	DN15,20	200	280	321	350	400	454	495	-----	-----	-----	-----	-----	-----	-----	-----	-----	-----
PT62-4.5	DN25	840	945	1049	1155	1358	1569	1673	-----	-----	-----	-----	-----	-----	-----	-----	-----	-----
PT62-10	DN15,20	135	150	166	180	210	241	255	280	300	350	391	405	420	-----	-----	-----	-----
PT62-10	DN25	604	654	710	760	870	974	1024	1079	1185	1290	1394	1499	1603	-----	-----	-----	-----
PT62-14	DN15,20	125	140	150	165	190	221	230	246	271	296	325	350	375	405	430	454	482
PT62-14	DN25	425	454	480	510	565	620	645	675	730	785	839	895	949	1004	1064	1120	1174

Recommended safety factor: steady condns. 1.5 - 2; fluctuating condns. 2-3

¹Indian Boiler Regulations

MATERIAL:

NO.	PART	MATERIAL	QTY.(Nos.)
1.	BODY	ASTM A216 Gr. WCB	01
2.	COVER	ASTM A216 Gr. WCB	01
3.	GASKET	CAF / Non CAF	01
4.	VALVE SEAT	13% CR STEEL / AISI 410/420	01
5.	BALL FLOAT & LEVER ASSY.	AISI 304	01
6.	AIR VENT	STAINLESS STEEL	01
7.	BOLT	ASTM A193 Gr. B7	04
8.	DRAIN PLUG	CARBON STEEL	01
9.	BRACKET ASSY.	AISI 304	01
10.	GASKET	COPPER	01
11.	SLR UNIT	AISI 304	01

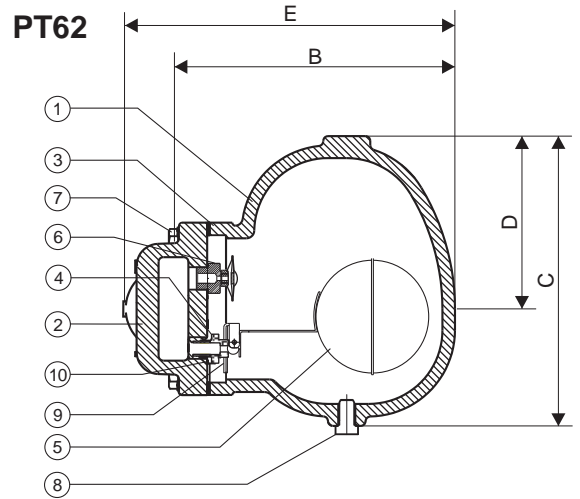

DIMENSIONS - Nominal in mm

SIZE	A	B	C	D	E	F	
						#150	#300
DN15	100	140	104	52	165	175	185
DN20	100	140	104	52	165	180	190
DN25	120	188	170	105	215	210	220

H	G
DN40 SCR	205
DN50 SCR	210
DN40 SW	195
DN50 SW	200

WEIGHTS - approx. in kg

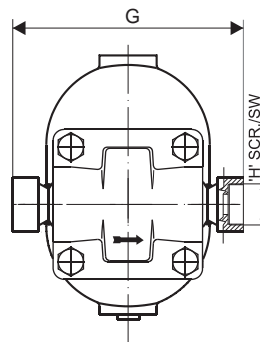
SIZE	SCREWED/ SW ENDS	FLANGED ENDS	
		#150	#300
DN15	4.5	5.4	5.9
DN20	4.5	5.8	6.5
DN25	7.5	11.5	12.5

AVAILABLE SPARES:

Valve Seat, Ball Float & Lever Assy., Airvent, Gaskets.

HOW TO ORDER:

PT62-4.5 DN25 BSP NIBR

ORDERING INFORMATION:

- 1) Inlet Pressure in bar (g)
- 2) Back Pressure in bar (g)
- 3) Operating Temperature in °C
- 4) Condensate Load in kg/hr
- 5) Size & Model
- 6) End Connections.
- 7) IBR / NIBR

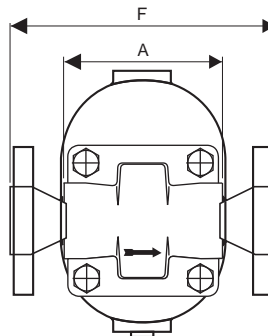
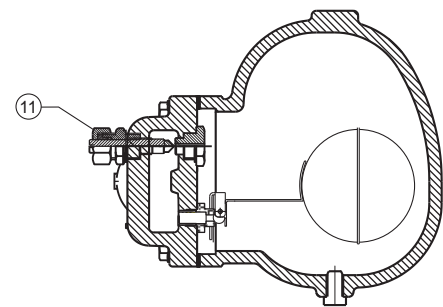
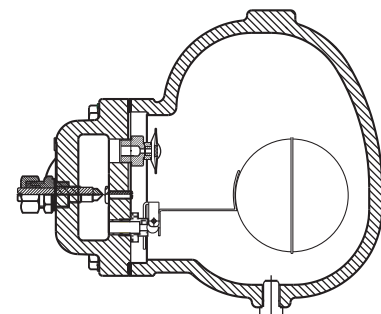
**PT62S STEAM LOCK
RELEASE (SLR)**

**PT62C THERMOSTATIC
AIR VENT + SLR**

Local regulations may restrict the use of this product below the conditions quoted. Limiting conditions refer to standard connections only. In the interest of development and improvement of the product, we reserve the right to change the specifications without prior notice.