

DESCRIPTION:

All stainless steel ball float and thermostatic (integral air vent) steam traps are designed for draining condensate from all types of low and medium pressure steam heating and process equipment.

Typical applications include unit heaters, heat exchangers, driers and jacketed vessels.

AVAILABLE TYPES :

PT61SS - with Thermostatic Air Vent

SALIENT FEATURES:

Modulating discharge.

Discharges condensate at steam temperature.

Excellent air venting (by thermostatic air vent).

USE: Saturated and superheated steam.

SIZES: DN15, 20

CONNECTIONS: Screwed (NPT / BSPT / BSP)
Socket weld / Flanged*

*End connection flanges of Stainless steel are welded on.

LIMITING CONDITIONS:

PMA: Max allowable pressure	16 bar (g)
TMA: Max. allowable temperature	220 °C
PMO: Max. operating pressure	14 bar (g)
TMO: Max. operating temperature	220 °C
Body shell design rating	20 bar (g) 426 °C
Cold hydro test pressure	32 bar (g)

INSTALLATION:

Standard horizontal installation with flow from right to left PT61SS.

UPON REQUEST:

- Horizontal installation with flow from left to right PT61SS (L-R)
- Vertical installation with flow from top to bottom PT61SS (V).

Max. differential pressure range:

PT61SS-4.5 : 4.5 bar

PT61SS-10 : 10 bar

PT61SS-14 : 14 bar

The trap should be installed below the drain point of the equipment in a position so that the float arm is in a horizontal plane and the float rises and falls vertically, with the flow direction as indicated on the body.

The arrow on the nameplate should be pointing vertically upwards.

TRAP DISCHARGE CAPACITY IN kg/hr

MODEL	SIZE	DIFFERENTIAL PRESSURE (bar)																
		0.5	1	1.5	2	3	4	4.5	5	6	7	8	9	10	11	12	13	14
PT61SS-4.5	DN15,20	200	280	320	350	400	454	495	-----	-----	-----	-----	-----	-----	-----	-----	-----	-----
PT61SS-10	DN15,20	135	150	165	180	210	241	255	280	300	350	391	405	420	-----	-----	-----	---
PT61SS-14	DN15,20	125	140	150	165	190	221	230	246	271	296	325	350	375	404	430	454	482

Recommended safety factor: steady condns. 1.5 - 2; fluctuating condns. 2-3

MATERIAL:

No.	PART	MATERIAL	QTY.(Nos.)
1.	BODY	ASTM A351 Gr. CF8	01
2.	COVER PLATE	ASTM A351 Gr. CF8	01
3.	TOP COVER	AISI 304	01
4.	BALL FLOAT & LEVER ASSY.	AISI 304	01
5.	BRACKET ASSY.	AISI 304	01
6.	VALVE SEAT	13% Cr. STEEL / AISI 410/420	01
7.	AIR VENT ASSY.	STAINLESS STEEL	01
8.	COVER GASKET	CAF / Non CAF	01
9.	BOLT	STAINLESS STEEL	04
10.	DRAIN PLUG	STAINLESS STEEL	01
11.	GASKET	COPPER	01
12.	FLANGE	ASTM A182 Gr. F304	02

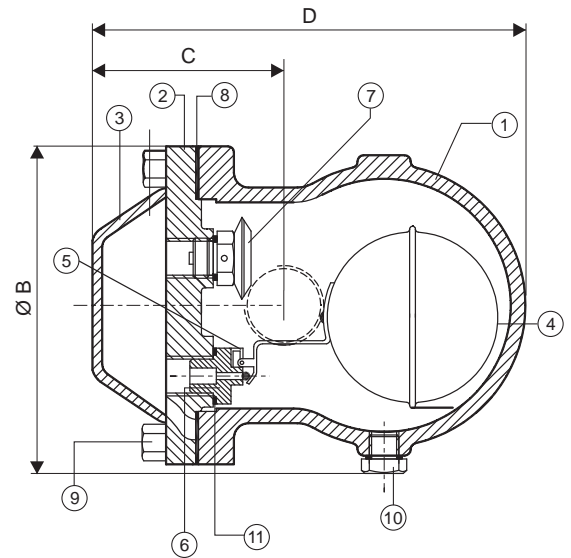

DIMENSIONS - Nominal in mm

Size	A	B	C	D	E	
					#150	#300
DN15,20	127	120	60	145	200	210

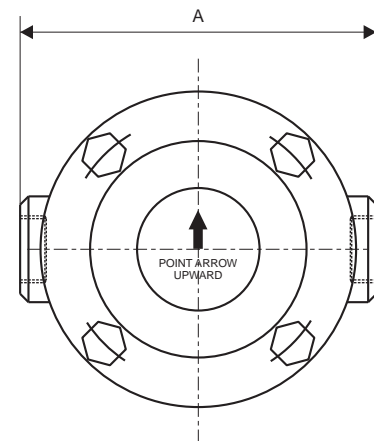

WEIGHTS: (approx.)

Size	SCR / SW	FLANGED	
		#150	#300
DN15	3.3 kg	4.6 kg	4.9 kg
DN20	3.3 kg	5.0 kg	5.8 kg

AVAILABLE SPARES:

Valve seat, Ball float & lever assy., Air vent, Gaskets.

HOW TO ORDER:

PT61SS-4.5 DN20 BSP

ORDERING INFORMATION:

- 1) Inlet Pressure in bar (g)
- 2) Back Pressure in bar (g)
- 3) Operating Temperature in °C
- 4) Condensate Load in kg/hr
- 5) Size & Model
- 6) Horizontal / Vertical
- 7) End Connections..

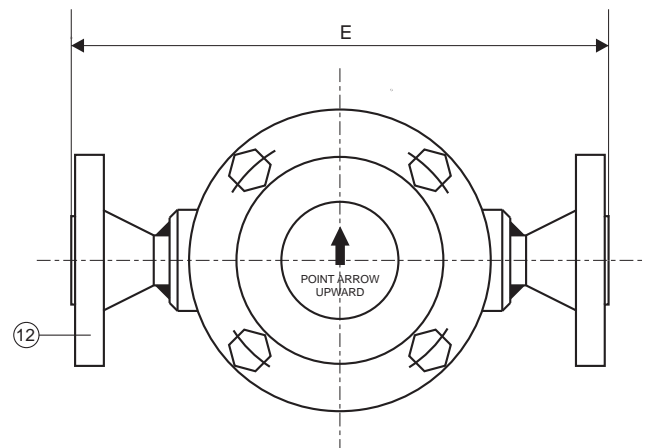

Local regulations may restrict the use of this product below the conditions quoted. Limiting conditions refer to standard connections only. In the interest of development and improvement of the product, we reserve the right to change the specifications without prior notice.