

DESCRIPTION :

High capacity thermostatic steam trap best suited for use in Clean Steam applications. All wetted parts of this trap are manufactured from FDA approved materials.

FEATURES :

- Full stainless steel 316L construction
- Condensate draining close to steam temperature ensuring min. condensate back up before discharge
- Highly polished for better cleanability and improved corrosion resistance. Surface finish Ra 0.4~0.8µm
- Compact and light weight
- Easy to install
- Ease in dismantling and cleaning.

APPLICATIONS :

- Sterilizers
- Autoclaves
- CIP/SIP systems
- Block and bleed systems
- Air venting of equipments
- Sterilization of equipments.

SIZES : DN15, 20

CONNECTIONS : Triclamp end

LIMITING CONDITIONS :

PMA: Max. allowable press.	10.5 bar(g)
TMA: Max. allowable temp.	177°C
PMO: Max. operating press.	7.0 bar(g)
TMA: Max. operating temp.	Saturation temperature

HOW TO ORDER:

PT34 DN15 BSP

ORDERING INFORMATION:

- 1) Inlet Pressure in bar (g)
- 2) Back Pressure in bar (g)
- 3) Operating Temperature in °C
- 4) Condensate Load in kg/hr
- 5) Size & Model
- 6) End Connections.
- 7) Sub cooling (°C)

Local regulations may restrict the use of this product below the conditions quoted. Limiting conditions refer to standard connections only. In the interest of development and improvement of the product, we reserve the right to change the specifications without prior notice.

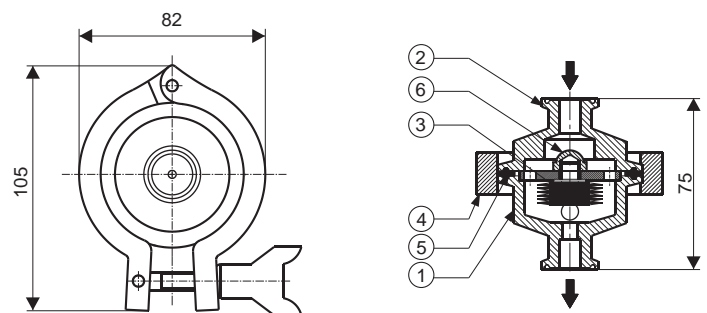

MATERIAL:

NO.	PART	MATERIAL	QTY. (Nos.)
1	BODY	AISI 316L	1
2	COVER	AISI 316L	1
3	CAPSULE	AISI 316L	1
4	CLAMP	AISI 304	1
5	GASKET	PTFE	1
6	SPRING	AISI 316L	1

INSTALLATION:

The trap is designed to fit in vertical direction with inlet from top and drain down, thus facilitating complete drain. Ensure that the installation is done as per flow direction marked on the body.

Do not expose the trap on superheated condition.

Do not depressurize the trap before it cools. This may damage / over expand the capsule.

