

### DESCRIPTION:

The PT33 is a balanced pressure thermostatic steam trap with "Y" type internal strainer. It is a perfect NO-LOSS steam trap that offers condensate sub-cooling to maximise thermal efficiency.

The highly responsive, corrosion and water-hammer resistant controller gives excellent deaeration and drainage.

Maximum thermal efficiency is automatically maintained under varying conditions.

### APPLICATIONS:

For drainage and deaeration of steam lines and all kinds of heat exchangers, (including those for superheated steam), auxiliary heating systems, sterilization systems, hot water heat exchangers, tracing and many other steam applications.

**SUB COOLING :** 12° C - Standard,  
6° C & 24° C - Optional

**SIZES :** DN15, 20

**CONNECTIONS :** Screwed (NPT/BSPT/BSP)  
Socket weld / Flanged.\*

\* End connection flanges of ASTM A105 forged carbon steel are welded on.

Non IBR<sup>1</sup> / IBR

### LIMITING CONDITIONS:

PMA: Max. allowable pressure	22 bar(g)
TMA: Max. allowable temp.	300 °C
PMO: Max. operating pressure	22 bar(g)
TMO: Max. operating temp.	250 °C
Cold hydro test pressure	44 bar(g)

### OPTIONAL:

Back-flow preventer: Stops reverse flow of the condensate when the plant is shut down.



### INSTALLATION:

1. Prior to installation, clean the lines by blowing through at full steam pressure to remove dirt. This should be strictly followed when the lines are new.
2. For steam trapping applications the trap should be fitted below the equipment to be drained and as close to the drain point as possible, preferably in a horizontal position with the cover on top.
3. For air venting applications, the trap should be fitted at the highest point of the piping system or equipment where the air / incondensable gases collect.

### MAINTENANCE:

This product can be maintained inline without disturbing the piping connections, provided isolation valves are fitted before and after the trap. Ensure that the trap is isolated - upstream and downstream - before attempting to dismantle it.

### IMPORTANT:

Do not de-pressurise the trap before it cools. Sudden loss of pressure in a trap which is hot causes permanent damage to the controller.

<sup>1</sup>Indian Boiler Regulations

**MATERIAL:**

NO.	PART	MATERIAL	QTY.(Nos.)
1.	BODY	ASTM A105	01
2.	COVER	ASTM A105	01
3.	STRAINER CAP	ASTM A743 Gr. CA40	01
4.	STRAINER SCREEN	AISI 304 (0.8 PERF.)	01
5.	VALVE SEAT	AISI 304	01
6.	THERMOSTATIC BELLOW	STAINLESS STEEL	01
7.	SPRING	AISI 304	01

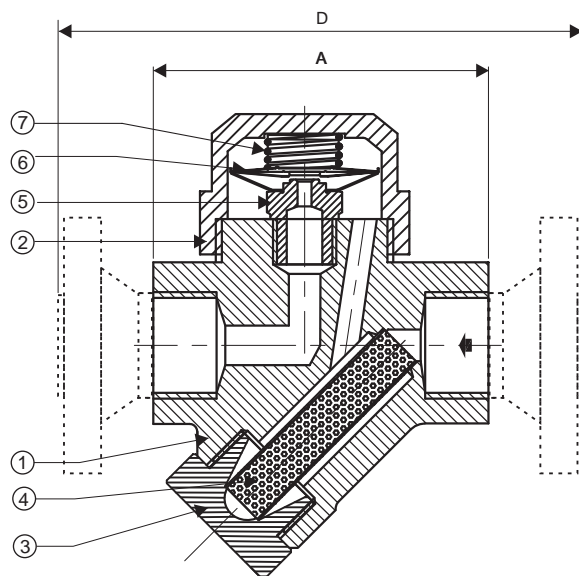
**DIMENSIONS - Nominal in mm**

Size	A	B	C	D	
				#150	#300
DN15	85	125	53	162	170
DN20	85	125	53	165	175

**WEIGHTS: (approx.)**

Size	SCR / SW	FLANGED	
		#150	#300
DN15	1.7 kg	3.0 kg	3.3 kg
DN20	1.7 kg	3.4 kg	4.2 kg

**AVAILABLE SPARES:**

Controller & Valve Seat Assy., Gaskets, Strainer Screen.

**HOW TO ORDER:**

PT33 DN15 BSP NIBR

**ORDERING INFORMATION:**

- 1) Inlet pressure bar (g)
- 2) Back pressure bar (g)
- 3) Operating temperature °C
- 4) Condensate load kg/hr
- 5) Size & Model
- 6) End Connections
- 7) Sub cooling °C
- 8) IBR / NIBR

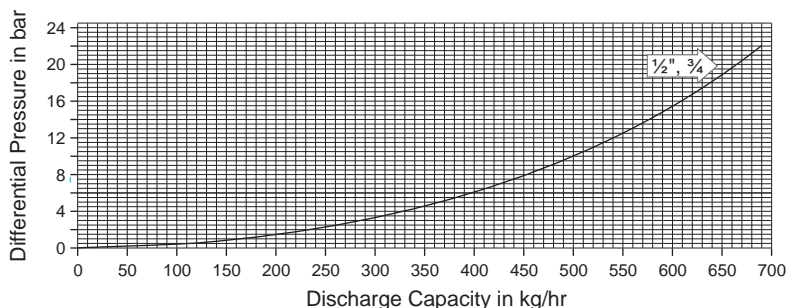
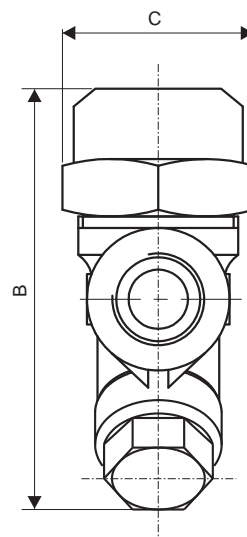

Local regulations may restrict the use of this product below the conditions quoted. Limiting conditions refer to standard connections only. In the interest of development and improvement of the product, we reserve the right to change the specifications without prior notice.