

DESCRIPTION:

Inverted bucket steam trap with integral strainer and all stainless steel internals. Best suited for equipment drains with medium to heavy condensate loads. Intermittent operation.

FEATURES:

The inverted bucket arrangement operates on the density difference between steam and water, giving a cyclic operation for discharge of the accumulated condensate.

High condensate handling capacities even at low pressure, permit the use of small trap sizes to suit many applications.

The valve and valve seat are hardened by a special induction hardening process to withstand continuous prolonged operation.

Perfect shut-off, no steam loss.

SIZES : DN15, 20, 25

CONNECTIONS: Screwed (NPT/BSPT/BSP)
Socket weld / Flanged*

*End connection flanges of ASTM A105 forged carbon steel are welded on

LIMITING CONDITIONS:

PMA: Max. allowable pressure	16 bar(g)
TMA: Max. allowable temp.	426 °C
Maximum operating back pressure at the outlet should not exceed 90% of the inlet pressure	
Minimum diff. pressure for satisfactory operation	0.1 bar
Cold hydro test pressure	32 bar(g)

INSTALLATION:

The trap should be fitted with the inlet and outlet connections horizontally in-line. Correct fitment with body vertical is essential for easy movement of the bucket. The bypass arrangement should be above the level of the trap.

Full port isolation valves should be fitted before and after the trap, to be used when the trap has to be opened for maintenance.



MAINTENANCE:

This product can be maintained inline without disturbing the piping connections. Ensure that the trap is isolated - upstream & downstream - before attempting to dismantle it. It is recommended that the trap be opened periodically and the internals inspected for wear, damage, and dirt. All worn or damaged parts should be replaced with new spares. A full new internal kit comprising of the valve pin, valve seat, bracket and lever, should be replaced as a set. The bucket vent hole should be cleaned. The strainer screen should be removed and cleaned regularly.

IMPORTANT:

Ensure that the trap is primed by opening the inlet valve only a crack at start-up, allowing water to fill the trap before the steam enters. The inlet valve should be opened fully only after the trap is filled with water.

The trap should be installed as close as possible to the equipment to be drained.

For new pipelines, ensure that the lines are properly flushed, prior to fitting the trap.

MATERIAL:

No.	PART	MATERIAL	QTY.(Nos.)
1.	BODY	ASTM A216 Gr. WCB**	01
2.	COVER	ASTM A216 Gr. WCB**	01
3.	BUCKET ASSLY.	AISI 304 with CS reinforcing ring where applicable	01
4.	LEVER ASSLY.	AISI 304	01
5.	VALVE SEAT (HARDENED)	13% CR STEEL / AISI 410/420	01
6.	BRACKET	AISI 304	01
7.	VALVE PIN (HARDENED)	13% CR STEEL / AISI 410/420	01
8.	STRAINER SCREEN	AISI304 (Perforated Sheet)	01
9.	STRAINER CAP	ASTM A743 Gr CA40	01
10.	GASKET (COVER)	CAF / Non CAF	01
11.	GASKET (STRAINER)	CAF / Non CAF	01
12.	BOLT	ASTM A193 Gr. B7	06
13.	PLUG	CARBON STEEL	02
14.	GASKET (PLUG)	CAF / Non CAF	02
15.	LOCATING TUBE	STAINLESS STEEL	01

**Can be supplied in ASTM A351 Gr. CF8 / CF8M on request

DIMENSIONS - Nominal in mm

MODEL	SIZE	A	B	C	D	Wt. SCR./SW	E	
							#150	#300
PT26-15	DN15	120	100	156	71	3.5 kg	197	205
PT26-20L	DN20						200	210
PT26-20	DN20	120	100	201	93	4.1 kg	200	210
PT26-25L	DN25						205	232

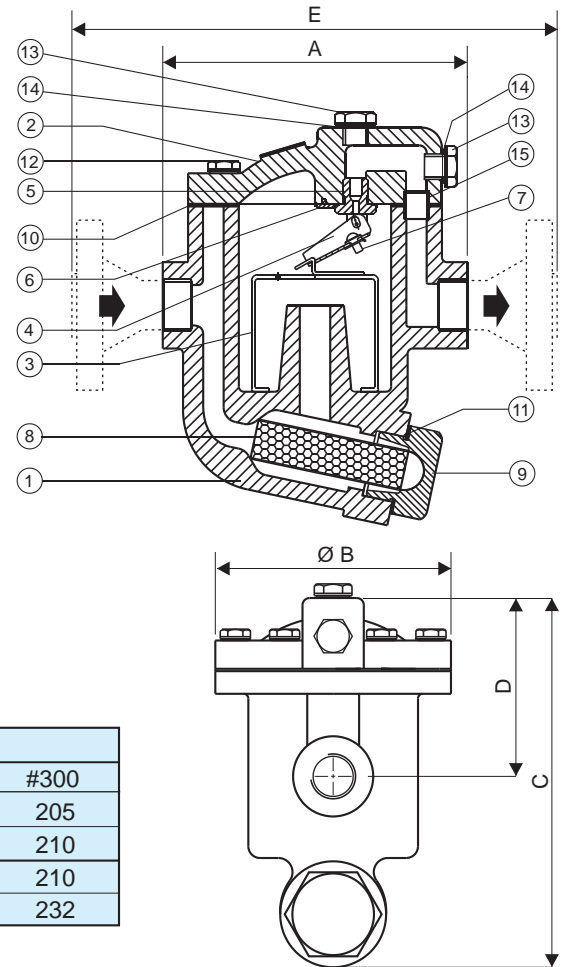
TRAP DISCHARGE CAPACITY IN kg/hr

Model	Orifice Size	DIFFERENTIAL PRESSURE (bar)											
		0.5	1.0	2.0	3.0	4.0	5.0	6.0	7.0	8.5	10.0	11.0	12.5
PT26-15 PT26-20L	2.5 mm	40	80	125	140	180	190	210	225	245	260	280	----
	2.8 mm	65	115	180	215	250	265	280	290	300	-----	-----	-----
	3.2 mm	110	160	210	250	280	-----	-----	-----	-----	-----	-----	-----
PT26-20 PT26-25L	2.8 mm	65	115	180	215	250	270	290	310	330	360	375	390
	3.2 mm	120	180	250	290	330	360	380	400	430	-----	-----	-----
	4.0 mm	160	225	310	350	410	-----	-----	-----	-----	-----	-----	-----

Guidelines on use of Capacity Chart

- Go to the differential pressure column corresponding to or slightly higher than, but not less than the operating differential pressure at which the trap is to be used. Move vertically downwards and select a suitable model and orifice size.
- The selected capacity should be equal to or higher than the condensate load after including a safety factor of 2 to 3. Oversizing is not recommended.
- Example - Operating conditions = I) Inlet press. 4bar(g) II) Back press. 1 bar(g) III) Condensate load 100 kg/hr. IV) Safety factor 2.

Model Selected: PT26-20 • Orifice Size : 2.8 mm • Capacity : 215 kg/hr @ a diff. press. of 3 bar.

HOW TO ORDER:

PT26-20L DN20 BSP P

ORDERING INFORMATION:

- 1) Inlet Pressure in bar (g)
- 2) Back Pressure in bar (g)
- 3) Operating Temperature in °C
- 4) Condensate Load in kg/hr
- 5) Size & Model
- 6) End Connections.

AVAILABLE SPARES:

SPARE KIT: Valve Pin, Valve Seat, Bracket & Lever Assly. (Op. diff. press. should be specified) Bucket Assly, Set of Gaskets, Strainer Screen.

Local regulations may restrict the use of this product below the conditions quoted. Limiting conditions refer to standard connections only. In the interest of development and improvement of the product, we reserve the right to change the specifications without prior notice.