

DESCRIPTION:

Strainers for steam, air, oil or water piping, protect equipment, steam traps, valves etc. from dirt, rust or scale, and debris, in the pipeline.

FEATURES:

Simple yet sound construction ensures long service life. A stainless steel strainer screen with a large surface area ensures minimum pressure drop and requires less frequent cleaning. Designed for easy in-line cleaning and maintenance.

LIMITING CONDITIONS:

PMA: Max. allowable pressure	40 bar (g)
TMA: Max. allowable temp.	340 °C
PMA / TMA for cast iron construction	17.5 bar(g) / 220°C
Cold hydro test pressure twice the Max. allowable pressure	

SIZES: DN 15, 20, 25, 40, 50

CONNECTIONS: Screwed (NPT, BSPT, BSP) / Socket Weld* (* Not Available In CI)

Non IBR¹ / IBR

IBR - Available only in CS / SS construction

MATERIAL:

No.	PART	MATERIAL	QTY. (Nos.)
1.	Body	CS / SS / CI	01
2.	Strainer Cap	CS / SS	01
3.	Strainer Screen	AISI 304 (40 mesh) ⁺	01
4.	Gasket	CAF / Non CAF	01

⁺Strainer Screen of 60 or 100 mesh available on request

DIMENSIONS - Nominal in mm

MODEL	SIZE	A	B	C	Wt.
PS11	DN15	75	69	91	0.82 kg
	DN20	75	69	91	0.77 kg
	DN25	95	87	114	1.6 kg
	DN40	190	157	202	6.850 kg
	DN50	190	157	202	6.0 kg

AVAILABLE SPARES:

Strainer Screen (Packet of 5)

¹Indian Boiler Regulations

Local regulations may restrict the use of this product below the conditions quoted. Limiting conditions refer to standard connections only. In the interest of development and improvement of the product, we reserve the right to change the specifications without prior notice.

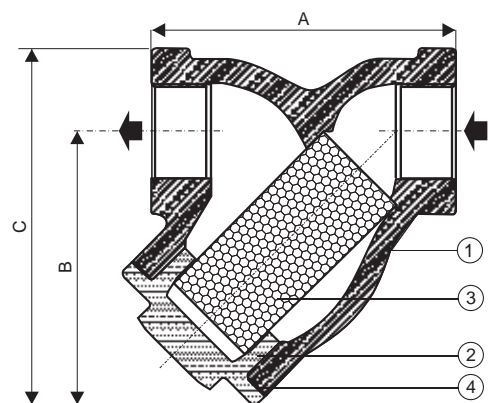
INSTALLATION:

For horizontal installations, the strainer should be installed with the screen in the horizontal plane or below the centre-line of the pipe. Ensure accessibility of the strainer cap for cleaning.

MAINTENANCE:

This product can be maintained without disturbing the piping connections. Complete isolation of the strainer from both supply and return lines is required before any servicing is carried out.

The strainer should be disassembled periodically for cleaning the screen.

IMPORTANT:

For new pipelines, ensure that the lines are properly flushed, prior to fitting the strainer.

HOW TO ORDER:

PS11 DN15 BSP NIBR

ORDERING INFORMATION:

- | | |
|--------------------------------|-----------------------------|
| 1) Inlet Pressure in bar (g) | 4) End Connections. |
| 2) Operating Temperature in °C | 5) IBR / NIBR |
| 3) Size & Model | 6) Material of construction |