

### DESCRIPTION:

PG71 sight glasses are designed to check the flow of cooling water, lubricants, air, steam, etc. in a pipe line. They may also be used to check the functioning of steam traps. This simple device is also an effective back-flow preventer.

Suitable for horizontal installation.

USE: Water, oil, steam, air and other non-corrosive media.

SIZES: DN15, 20, 25, 40, 50

CONNECTIONS: Screwed (NPT/BSPT/BSP)

### LIMITING CONDITIONS: (for steam)

Maximum allowable pressure	16 bar(g)
Maximum allowable temperature	200 °C
Cold hydro test pressure	32 bar(g)

### INSTALLATION:

The sight glass should be installed in a horizontal pipe line with the glass at the top. Enough space should be left open above the glass to facilitate checking of the flow/operation. In cases where the device is fitted to check the operation of a steam trap, it should be fitted at a distance of 5 to 6 feet (approx. 2 m) downstream of the trap.

### MATERIAL:

No.	PART	MATERIAL	QTY. (Nos)
1.	BODY	CAST IRON	01
2.	COVER	CAST IRON	01
3.	GLASS	Toughened Borosilicate	01
4.	BALL	PTFE	01
5.	GASKETS	CAF / Non CAF	02

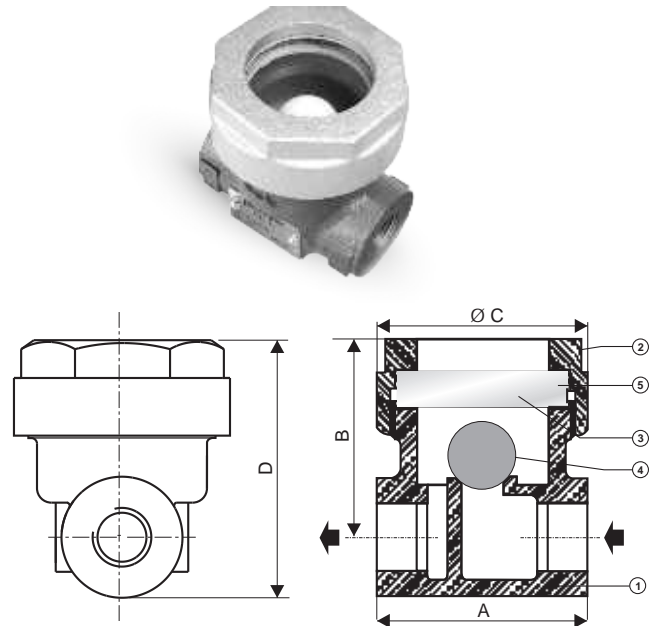

### DIMENSIONS - Nominal in mm

SIZE	A	B	C	D	Wt.
DN15	84	72	76	92	1.4 kg
DN20	84	72	76	92	1.4 kg
DN25	84	76	76	101	1.6 kg
DN40,50	127	89	76	127	4.25 kg

### DISCHARGE CAPACITY IN kg/hr (For hot condensate)

Model/Size	DIFFERENTIAL PRESSURE (bar)																
	0.25	1.0	2.0	3.0	4.0	5.0	6.0	7.0	8.0	9.0	10.0	11.0	12.0	13.0	14.0	15.0	16.0
PG71-DN15	1055	1190	1375	1560	1740	1925	2100	2290	2475	2655	2840	3020	3200	3390	3570	3750	3935
PG71-DN20	1450	1625	1860	2100	2335	2570	2800	3045	3280	3515	3755	3990	4220	4455	4695	4930	5165
PG71-DN25	1520	1740	2020	2320	2610	2885	3190	3475	3770	4055	4355	4650	4930	5220	5510	5800	6090
PG71-DN40,50	2650	3050	3625	4230	4865	5310	5895	6310	7120	7850	8200	8500	8690	8860	9045	10100	10280

### HOW TO ORDER:

PG71 DN25 BSP

### ORDERING INFORMATION:

- 1) Inlet Pressure in bar (g)
- 2) Back Pressure in bar (g)
- 3) Operating Temperature in °C
- 4) Condensate Load in kg/hr
- 5) Size & Model
- 6) End Connections.

### AVAILABLE SPARES:

Set of Glass, Ball, Gaskets.

Local regulations may restrict the use of this product below the conditions quoted. Limiting conditions refer to standard connections only. In the interest of development and improvement of the product, we reserve the right to change the specifications without prior notice.