

DESCRIPTION :

Blow-down valve in complete stainless steel construction. Suitable for blowing out unwanted loose material collected in the strainer element. Also used to blow down the system pressure from the device during shutdown.

FEATURES :

Stainless steel construction ensures excellent mechanical & corrosion resistant properties. Specially designed screw mechanism ensures that the operator is clear of the blow down stream.

Tight shut off when in closed condition.

Available in various sizes.

Easy to operate.

Maintenance free.

SIZES : DN15, 20, 25

CONNECTION : Screwed (BSP/BSPT/NPT)

Non IBR¹ / IBR approved.

LIMITING CONDITIONS :

PMA: Max. allowable pressure	42 bar(g)
TMA: Max. allowable temp.	426 °C
Cold hydro test pressure	84 bar(g)

INSTALLATION :

Blow-downs are screwed on to the trap body at the drain point or where the strainer element is fitted. The direction of the outlet of blow down should be pointing away from the working area.

IMPORTANT :

Ensure that only a wrench is used for operating the blow-down valve. This will safeguard the operator at work.

NO SPARES AVAILABLE.

HOW TO ORDER:

BDV PT10 (for Pennant Traps)

BDV DN20 BSP (for other fitments)

¹Indian Boiler Regulations

Local regulations may restrict the use of this product below the conditions quoted. Limiting conditions refer to standard connections only. In the interest of development and improvement of the product, we reserve the right to change the specifications without prior notice.

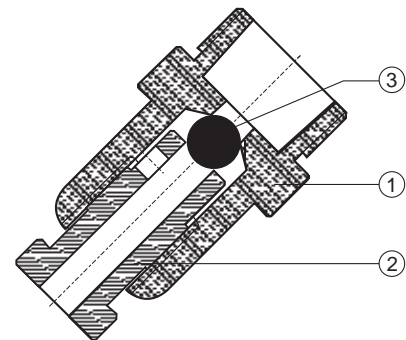

MATERIAL :

Sr. No.	PART	MATERIAL	QTY. (Nos)
1.	BODY	AISI 304	01
2.	SCREW	AISI 304	01
3.	BALL	AISI 420	01